

## PAJOT 1400 HAMMER

### SPECIFICATIONS

Approx. weight (without guide) . . . . .	1 400 kg
Approx. weight (with standard guide) . . . . .	2 000 kg
Impact energy at 8 bars . . . . .	700 kg.m
Blow rate . . . . .	240 BPM
Air required flow rate . . . . .	11 000 l./minute
Hose diameter . . . . .	40 mm

#### This hammer can be fitted with :

- ⋮ 1 rectangular anvil
- ⋮ 1 square anvil
- ⋮ Under water job



### FURTHER INFORMATIONS - - -

**Maximum practical load able to be exerted on a pile : 26 t.**

#### Work capacity in an average ground :

- ⋮ 400 mm single **sheet pile**,  
10 à 11 meters in ground  
(8 meters for double sheet piles)
- ⋮ **Pointing closed tubes** diam.  
250 mm, 20 meters in ground
- ⋮ **Open tubes** diam. 350 mm,  
11 meters in ground



## PAJOT 1400 HAMMERS

### EQUIPMENTS

Specials guides on request, contact us

Adjustable standard guide :

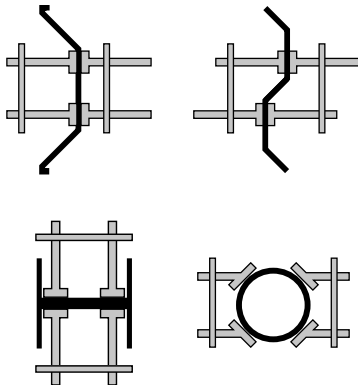

Adjustable standard guide for sheet piles or H from 240 mm inside

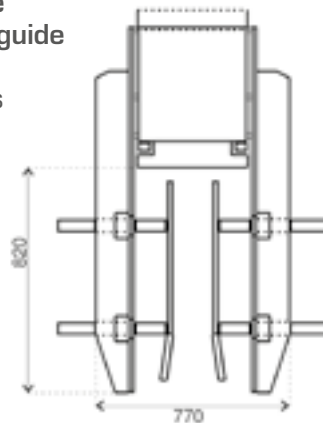

New adjustable pile guide :

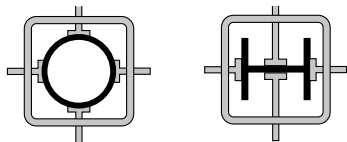

Standard pile guide for max 315 mm

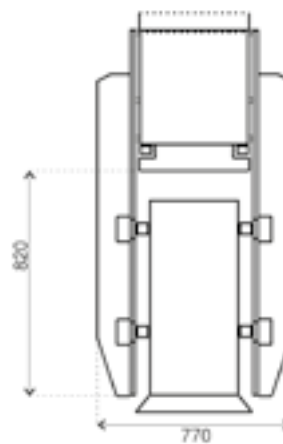

New model adjustable from 100 to 370 mm

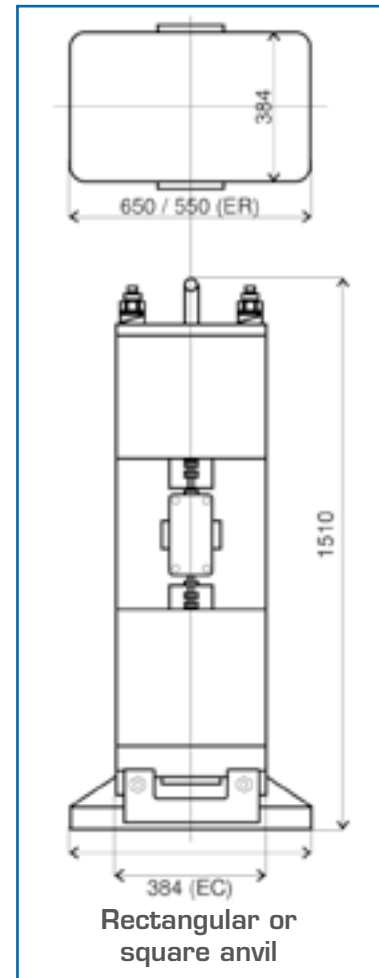

Noise abatement cover available for all hammers

