

PAJOT 3600 HAMMERS

SPECIFICATIONS

Approx. weight (without guide)	3 600 kg
Approx. weight (with standard guide)	4 700 kg
Impact energy at 8 bars	2 514 kg.m
Blow rate	160 BPM
Air required flow rate	25 000 to 30 000 l./minute
Hose diameter	50 mm

This hammer can be fitted with :

- :::: 1 rectangular anvil
- :::: 1 square anvil
- :::: Under water job set-up



FURTHER INFORMATIONS

Maximum practical load able to be exerted on a pile : 95 t.

Work capacity in an average ground :

::::: **Double sheet piles,**
18 to 20 meters in ground

::::: **Open tubes diam. 350 mm,**
18 meters in ground



PAJOT 3600 HAMMERS

EQUIPMENTS

Specials guides on request, contact us

Adjustable standard guide :

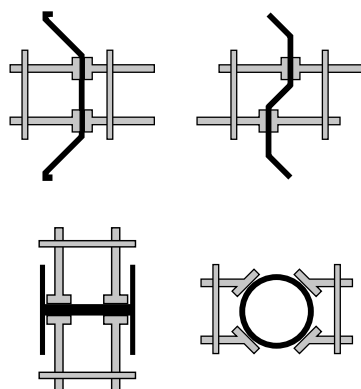

Adjustable standard guide for small width sheet pile 600 mm and double sheet pile or H from 260 mm inside.

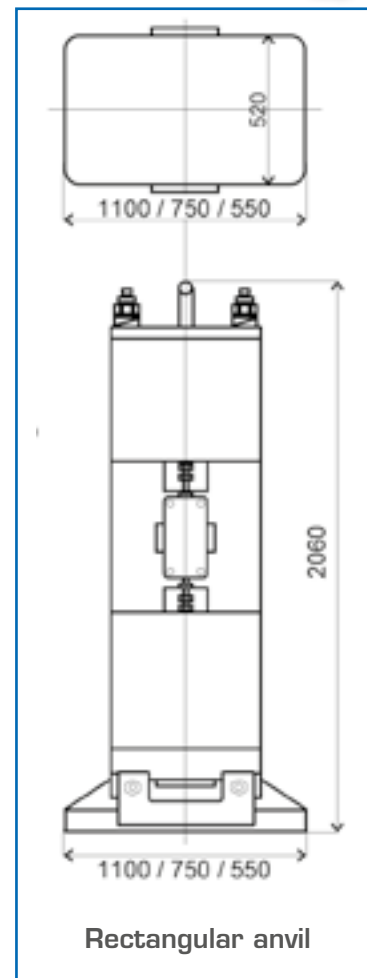
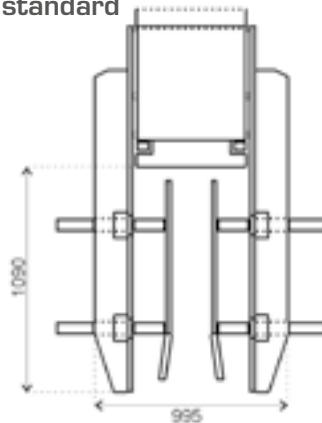

New adjustable pile guide :

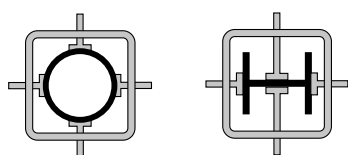

Standard pile guide for max 450 mm

New model adjustable from 100 to 5100 mm

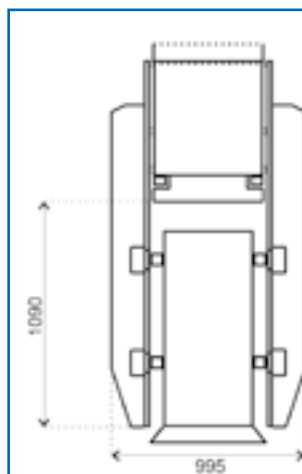

Contact us for special guide of tubes \varnothing 500 to 900 mm (special guide with spreader plate).

Noise abatement cover available for all hammers

