

## FICHE TECHNIQUE

### ENSEMBLE VIBREUR HAUTE FRÉQUENCE À MOMENT VARIABLE PVE 2310VM

#### VIBREUR 2310VM

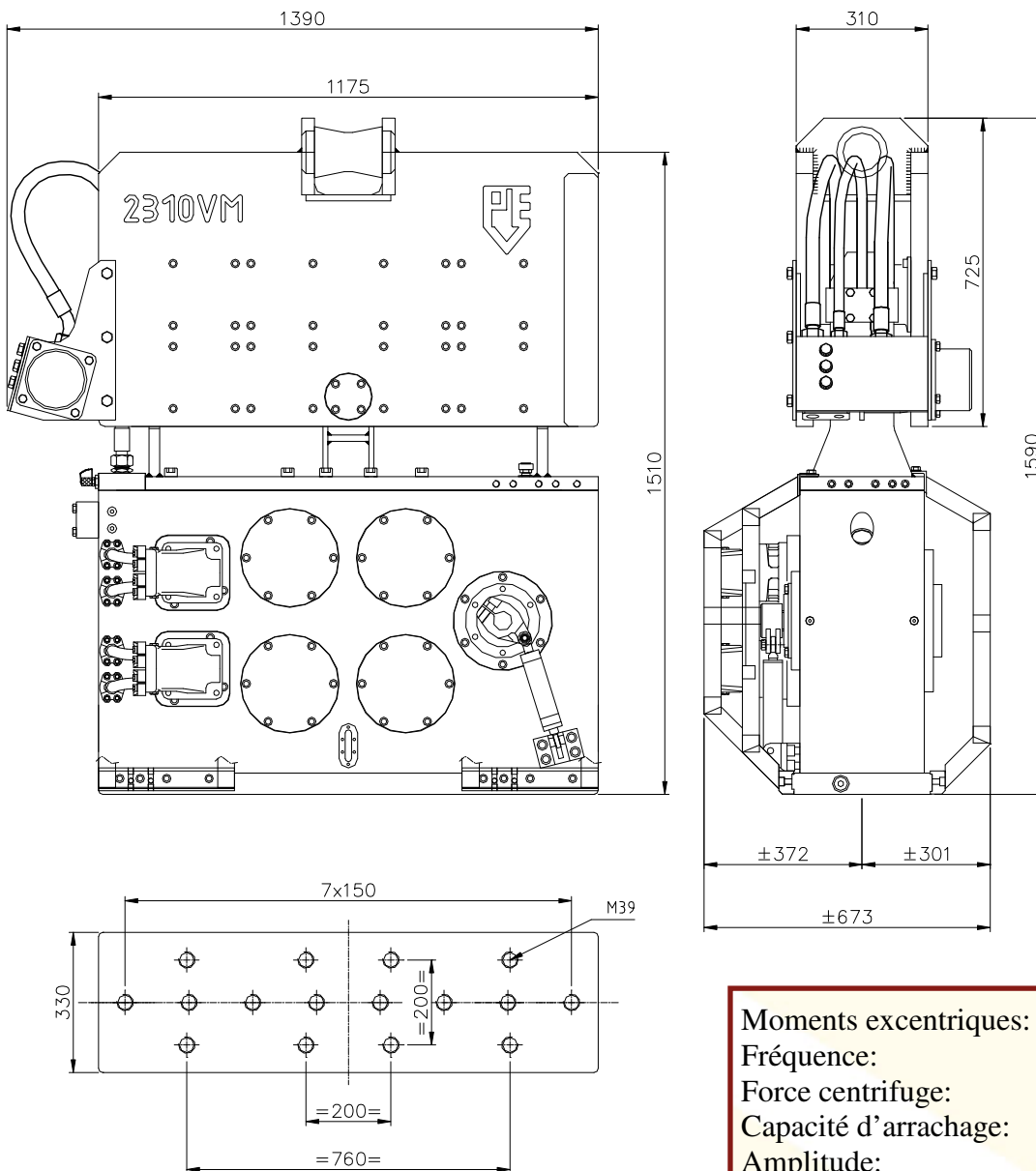

Moments excentriques:	0-10	kgm
Fréquence:	2300	t/m
Force centrifuge:	0-580	kN
Capacité d'arrachage:	200	kN
Amplitude:	0-14	mm
Masse totale :	1900	kg
Masse dynamique:	1450	kg
Débit:	261	l/min
Max.Pression:	350	bar

## CENTRALE HYDRAULIQUE 280

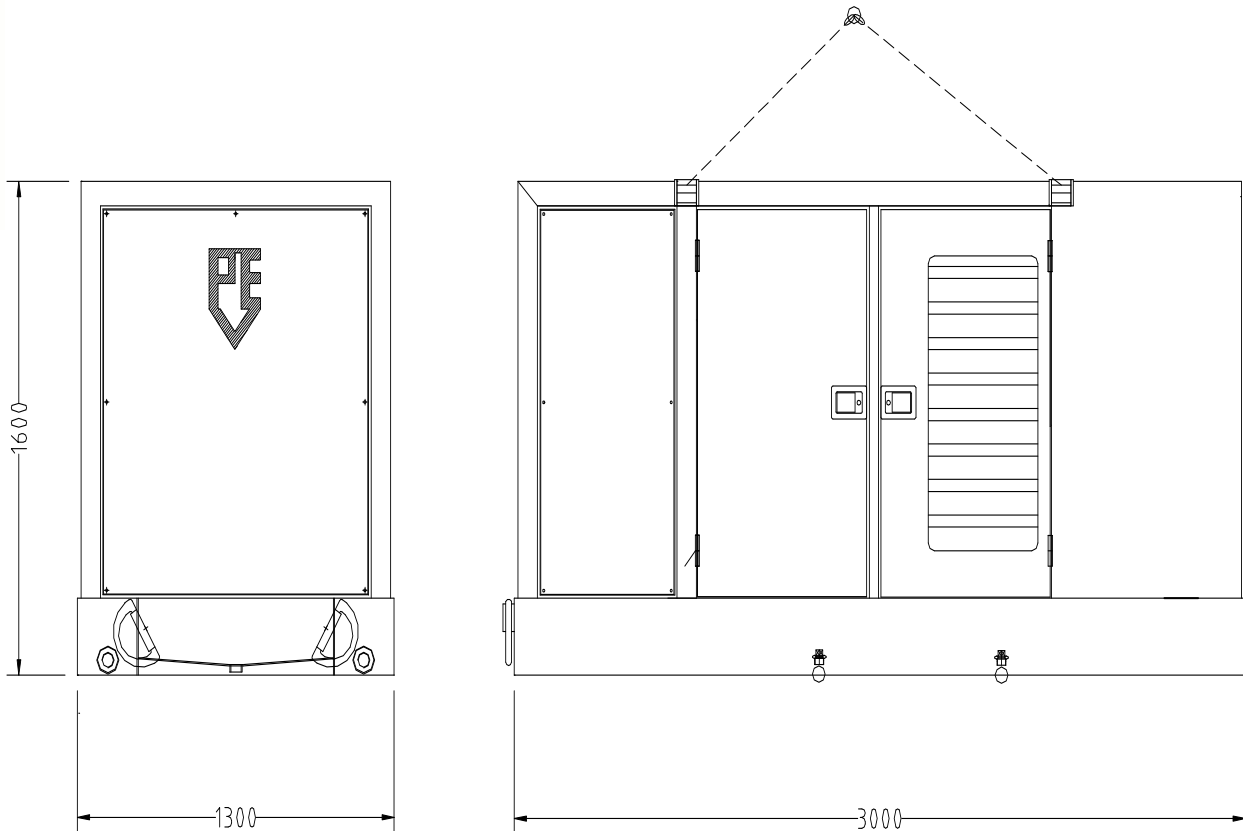

Moteur diesel:	Cummins	
Puissance:	190/260	kW/CV
Débit:	280	l/min
Max Pression:	350	bar
Poids:	3500	kg
Cap. res. diesel:	450	L
Cap. res. huile d'Hyd:	500	L

**PINCE À PALPLANCHE 85T**

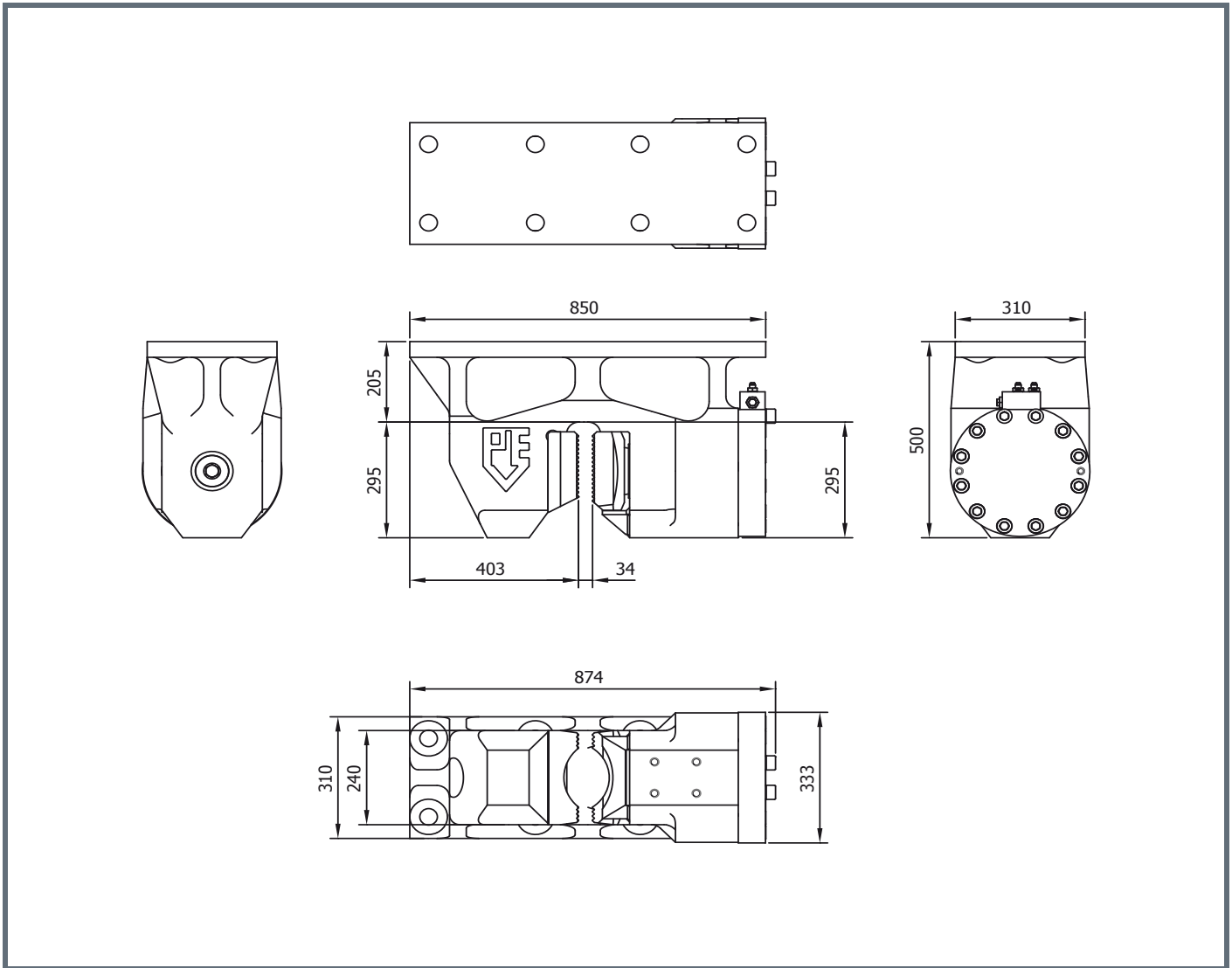

Specifications	Technische Daten	Spécifications	Specificaties	Especificacions
Sheet pile clamp	Spundwandzange	Pince palplanches	Damwandklem	Hoja abrazadera pila
Clamping force	850 kN	Klemmkraft	Klemkracht	Fuerza de sujeción
Max. operating press.	300 bar	Max. Betriebsdruck	Max. werkdruk	Presión máx. de trabajo
Max. clamp open press.	180 bar	Max. Druck Zange Offen	Max. klem open druk	Presión abrazadera aperto máx.
Weight	600 kg	Gewicht	Gewicht	Peso

**CASQUE A TUBE 55T**

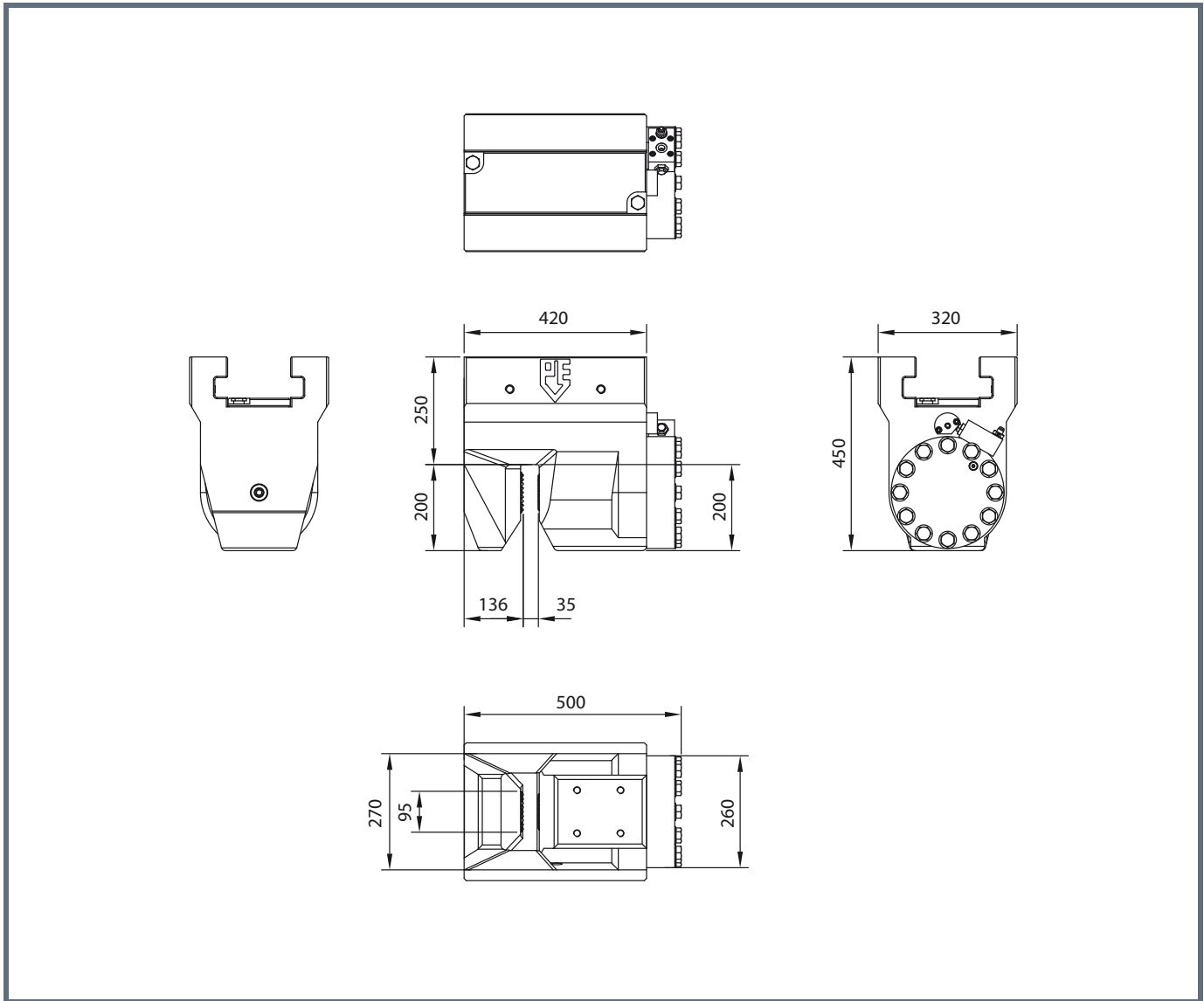

Specifications		Technische Daten	Spécifications	Specificaties	Especificacions
Tube clamp		Rohrklemm	Pince tube	Pijpenklem	Abrazadera de tubo
Clamping force	550 kN	Klemmkraft	Force de serrage	Klemkracht	Fuerza de sujeción
Max. operating press.	300 bar	Max. Betriebsdruck	Pression de travail max.	Max. werkdruk	Presión máx. de trabajo
Max. clamp open press.	180 bar	Max. Druck Zange Offen	Pression pince ouvert max.	Max. klem open druk	Presión abrazadera aperto máx.
Weight	310 kg	Gewicht	Poids	Gewicht	Peso